



**ASHBURN  
AULT COMPANY, Inc.**  
18 Washburn Way  
Hinsdale, NH 03451

*Precast Concrete • Redi Mix*

**NOTES:**

- \*Reinforcing Steel Deformed bars conform to latest ASTM specification A615.
- \* Concrete compressive strength 5000 PSI at 28 days.
- \*Method of manufacture: Wet Cast
- \*Section is Monolithic
- \*Pipe inlet and outlets have Polylok pipe seals
- \*Design load: AASHTO H-20
- \*Tank design specifications conform to ASTM C913 and C1227
- \*Joint sealant conforms to latest AASHTO specification M-198.

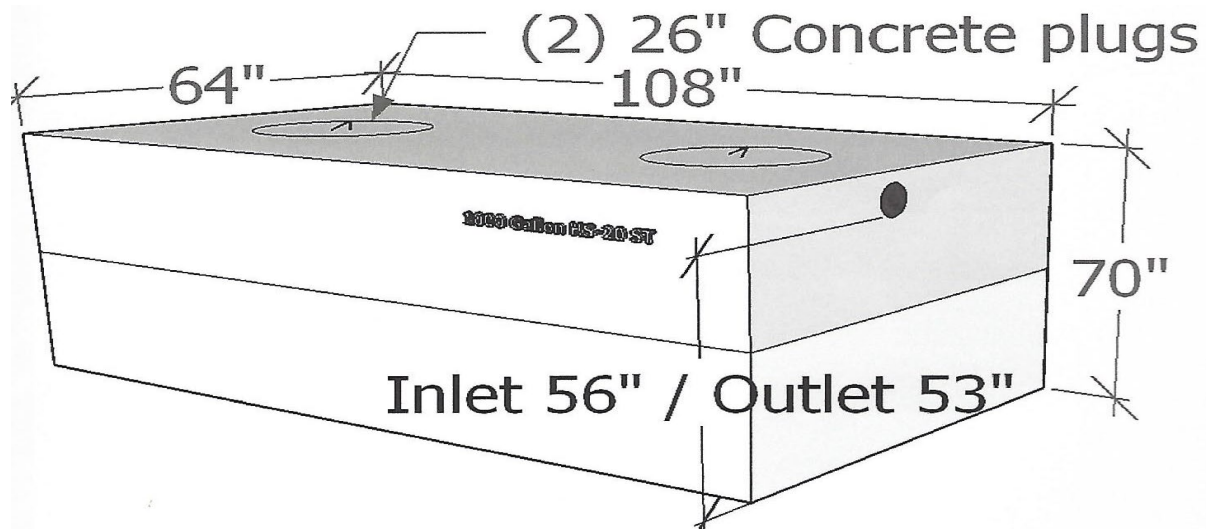

# 1000 GALLON HS-20 ST

Phone: 603-256-6891

WEIGHT: 15,500 LBS.

E-MAIL: WASHBURNVAULT@YAHOO.COM

DATE: 1/1/2017