



**ASHBURN  
AULT COMPANY, Inc.**  
18 Washburn Way  
Hinsdale, NH 03451

*Precast Concrete • Redi Mix*

**NOTES:**

\*Reinforcing Steel Deformed bars conform to latest  
ASTM specification A615.

\* Concrete compressive strength 4000 PSI at 28 days.

\*Method of manufacture: Wet Cast

\*Section is Monolithic

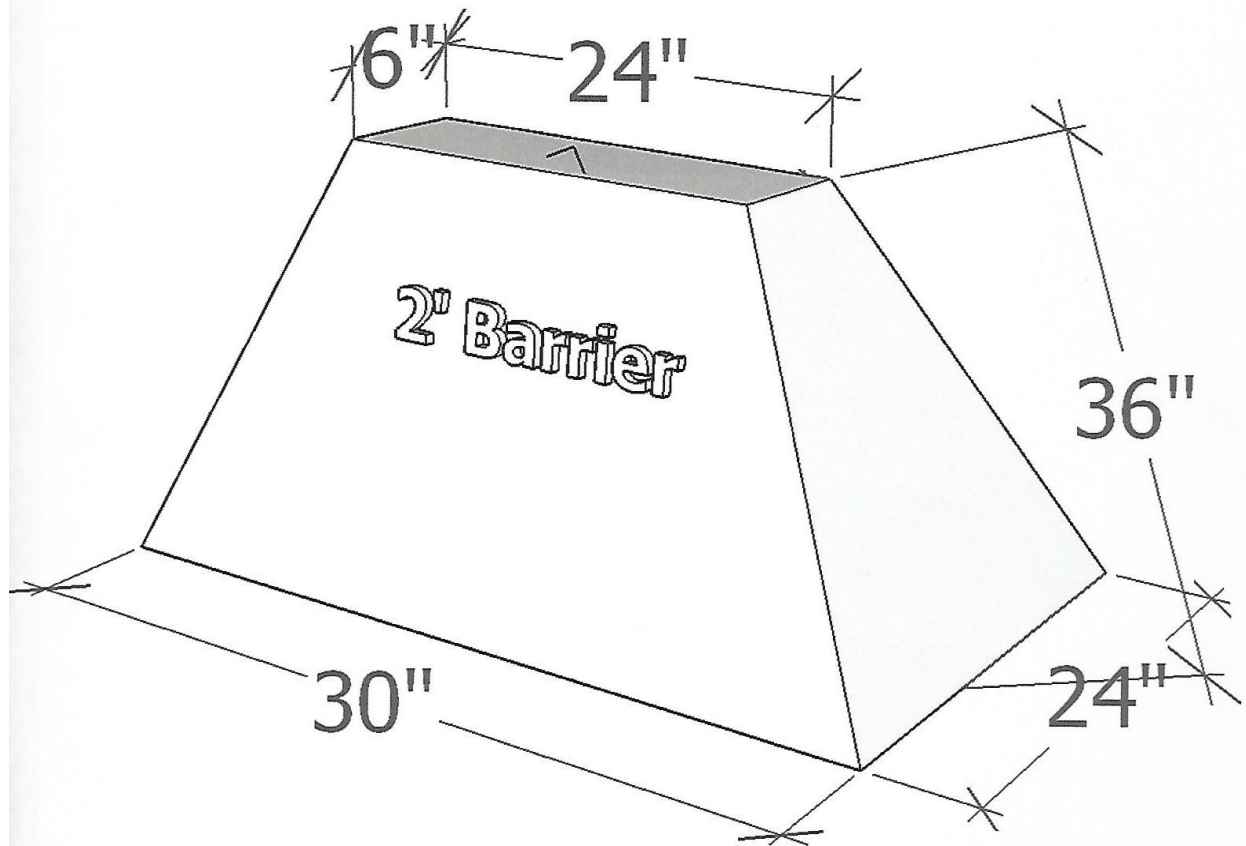

# 2' BARRIER

Phone: 603-256-6891

WEIGHT: 1,100 LBS

E-MAIL: WASHBURNVAULT@YAHOO.COM

DATE: 1/1/2017