



**ASHBURN
AULT COMPANY, Inc.**
18 Washburn Way
Hinsdale, NH 03451

Precast Concrete • Redi Mix

NOTES:

- *Reinforcing Steel Deformed bars conform to latest ASTM specification A615.
- * Concrete compressive strength 4000 PSI at 28 days.
- *Method of manufacture: Wet Cast
- *Section is Monolithic
- *Bolts and template supplied by others
- *Conduits 1" typical to specified locations

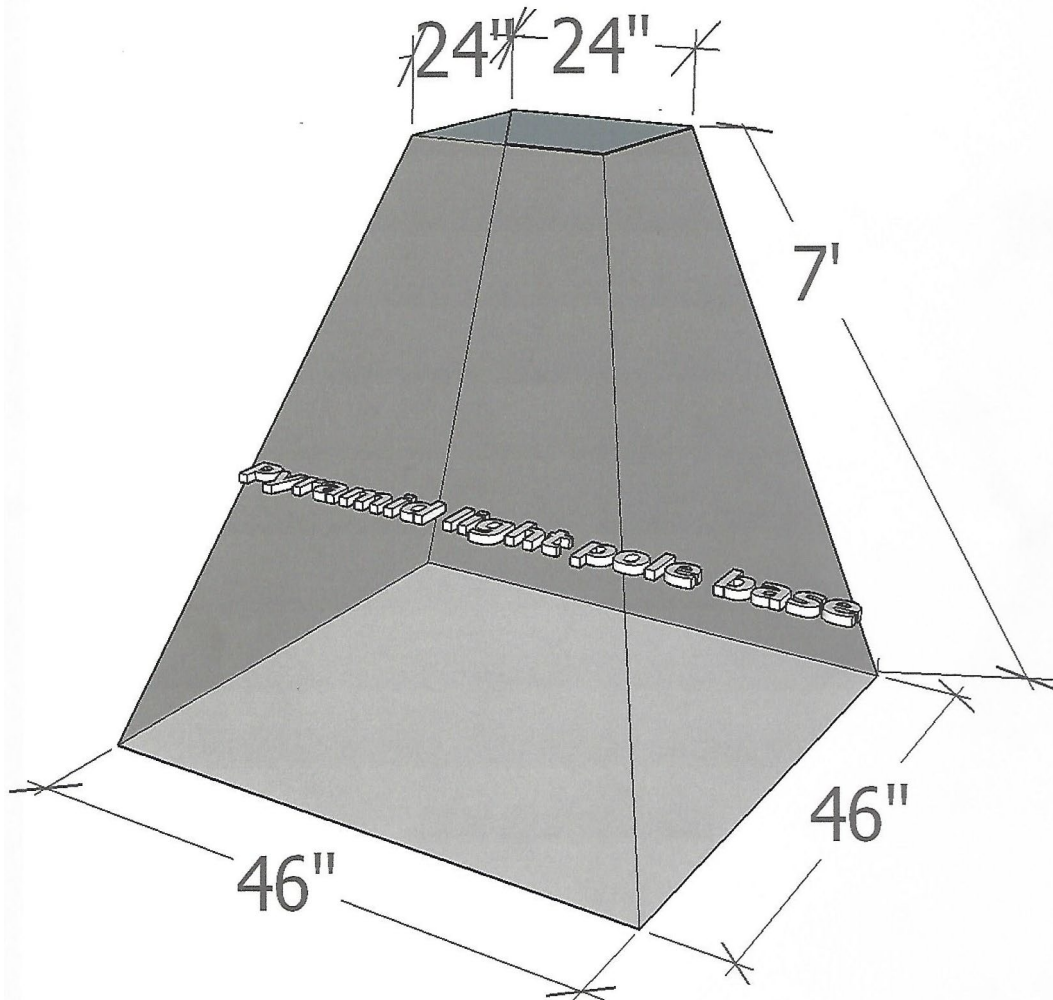

PYRAMID LIGHT POLE BASE

WEIGHT: 9,500 LBS.

Phone: 603-256-6891

E-MAIL: WASHBURNVAULT@YAHOO.COM

DATE: 1/1/2017