



**ASHBURN
VAULT COMPANY, Inc.**
18 Washburn Way
Hinsdale, NH 03451

Precast Concrete • Redi Mix

NOTES:

*Reinforcing Steel Deformed bars conform to latest ASTM specification A615.

* Concrete compressive strength 4000 PSI at 28 days.

*Method of manufacture: Wet Cast

*Section is Monolithic

*Pipe inlet and outlets have Polylok pipe seals

*Tank design specifications conform to ASTM C913 and C1227

*Joint sealant conform to latest AASHTO specification M-198

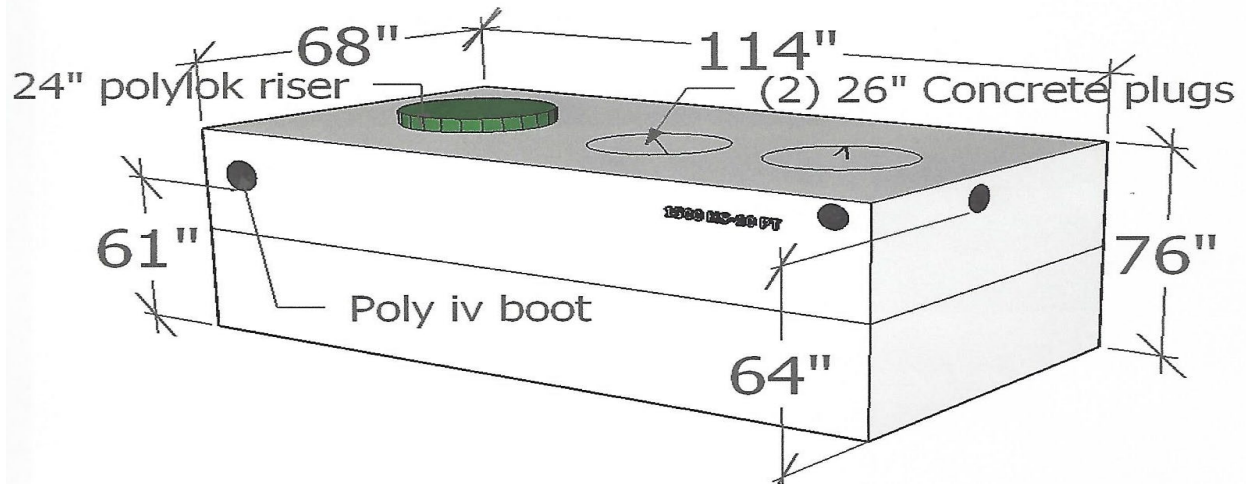

1500 GALLON HS-10 PT

Phone: 603-256-6891

WEIGHT: 14,000 LBS.

E-MAIL: WASHBURNVAULT@YAHOO.COM

DATE: 1/1/2017