



**ASHBURN
AULT COMPANY, Inc.**
18 Washburn Way
Hinsdale, NH 03451

Precast Concrete • Redi Mix

NOTES:

- *Reinforcing Steel Deformed bars conform to latest ASTM specification A615.
- * Concrete compressive strength 4000 PSI at 28 days.
- *Method of manufacture: Wet Cast
- *Section is Monolithic
- *Pipe inlet and outlets have Polylok pipe seals
- *Tank design specifications conform to ASTM C913 and C1227
- *Joint sealant conform to latest AASHTO specification M-198

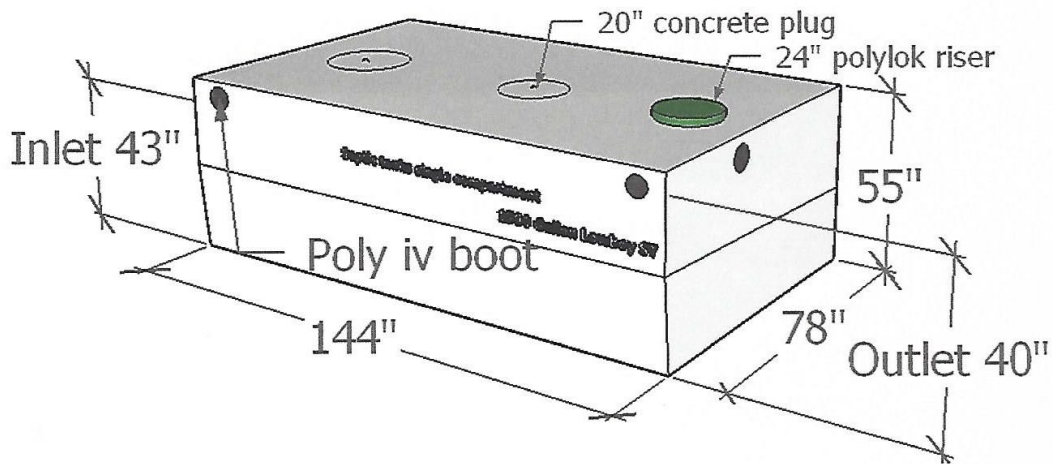

1500 GALLON LOWBOY ST

Phone: 603-256-6891

WEIGHT: 14,000 LBS.

E-MAIL: WASHBURNVAULT@YAHOO.COM

DATE: 1/1/2017